

SP4”

4-Inch Stainless Steel Submersible Pumps

US Installation and operating instructions



WATER QUALITY
DRINKING WATER
SYSTEM COMPONENTS
ANSI/NSF 61
65 GM
30°C/86°F
PUMP END ONLY



Please leave these instructions with the pump for future reference.

SAFETY WARNING

WARNING: Reduced risk of electric shock during operation of this pump requires the provision of acceptable grounding. If the means of connection to the supply connected box is other than grounded metal conduit, ground the pump back to the service by connecting a copper conductor (at least the size of the circuit supplying the pump) to the grounding screw provided within the wiring compartment.

NOTICE: This product is designed for pumping water only. Third party agency evaluations are based on pumping water only.

Pre-Installation Checklist

1. Well Preparation

If the pump is to be installed in a new well then the well should be fully developed and bailed or blown free of cuttings and sand. The stainless steel construction of the GRUNDFOS submersibles make it resistant to abrasion; however, no pump made of any material can forever withstand the destructive wear that occurs when constantly pumping sandy water.

If this pump is used to replace an oil-filled submersible or oil-lubricated line-shaft turbine in an existing well, the well must be blown or bailed clear of oil.

2. Make Sure You Have The Right Pump

Determine the maximum depth of the well, and the draw-down level at the pump's maximum capacity. Pump selection and setting depth should be based on this data.

3. Pumped Fluid Requirements

CAUTION: Submersible well pumps are designed for pumping clear, cold water; free of air or gases. Decreased pump performance and life expectancy can occur if the water is not cold, clear or contains air or gasses. Water temperature should not exceed 102°F.

A check should be made to ensure that the installation depth of the pump will always be at least three feet below the maximum drawdown level of the well. The bottom of the motor should never be installed lower than the top of the screen or within five feet of the well bottom.

Ensure that the requirement for minimum flow past the motor is met, as shown in the table below:

Minimum Water Flow Requirements for Submersible Pump Motors

| MINIMUM DIAMETER | CASING OR SLEEVE I.D. IN INCHES | MIN. GPM FLOW PASSING THE MOTOR |
|------------------|---------------------------------|---------------------------------|
| 4-Inch | 4 | 1.2 |
| | 5 | 7 |
| | 6 | 13 |
| | 7 | 21 |
| | 8 | 30 |

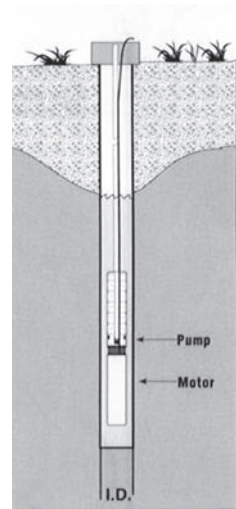

NOTES: For proper motor cooling, a flow inducer or sleeve must be used if the water enters the well above the motor or if there is insufficient water flow past the motor. The minimum water velocity past 4" motors is 0.25 feet per second.

PRE-INSTALLATION CHECKLIST

4. Splicing the Motor Cable

If the splice is carefully made, it will be as efficient as any other portion of the cable, and will be completely watertight. There are a number of cable splicing kits available today – epoxy filled, rubber-sealed and so on. Many perform well if the manufacturer's directions are followed carefully. If one of these kits is not used, we recommend the following method for splicing the motor cable.

Examine the motor cable and drop cable carefully for damage. Cut the motor leads off in a staggered manner. Cut the ends of the drop cable so that the ends match up with the motor leads. Be sure to match the colors. Strip back and trim off one-half inch of insulation from each lead, making sure to scrape the wire bare to obtain a good connection. Be careful not to damage the copper conductor when stripping off the insulation. Insert a properly sized Sta-kon-type connector on each pair of leads, again making sure that colors are matched. Using Sta-kon crimping pliers, indent the lugs. Be sure to squeeze down hard on the pliers, particularly when using large cable. Form a piece of electrical insulation putty tightly around each Sta-Kon. The putty should overlap on the insulation of the wire. Use a good quality tape such as **#33 Scotch Waterproof** or **Plymouth Rubber Company Slipknot Grey**. Wrap each wire and joint tightly for a distance of about 2-1/2 inches on each side of the joint. Make a minimum of four passes over each joint and overlap each pass approximately one inch to assure a completely watertight seal.

INSTALLATION PROCEDURES

1. Attach the Pump to the Motor

When attaching the pump to the motor we recommend the pump be bolted down in a cross pattern around the four bolts. Starting from the back (opposite the cable opening) and using a cross pattern, tighten the motor bolts to 13.5 ft-lbs, using progressive tightening until torque is met. (See figure 1 for example).

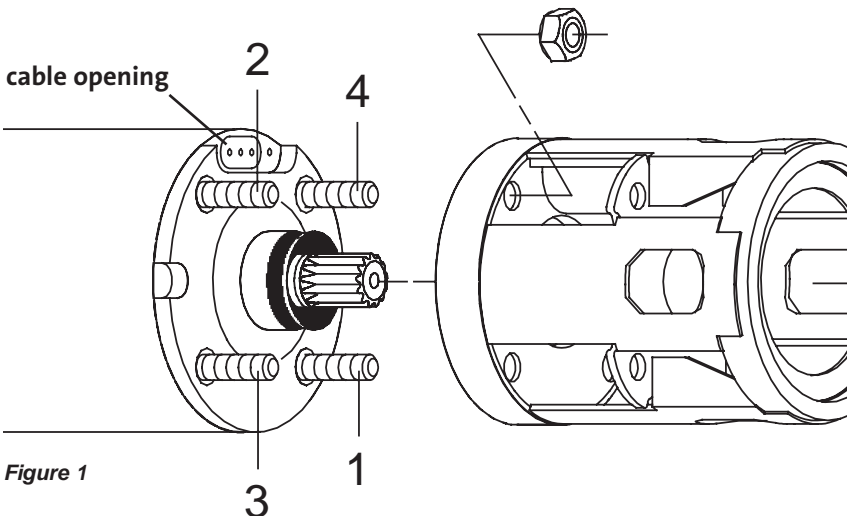

INSTALLATION PROCEDURES

2. Attach the Pump to the Pipe

A back-up wrench should be used when riser pipe is attached to the pump. The pump should only be gripped by the flats on the top of the discharge chamber. Under no circumstances grip the body of the pump, cable guard or motor. When tightened down, the threaded end of the first section of the riser pipe or the nipple must not come in contact with the check valve retainer in the discharge chamber of the pump. After the first section of the riser pipe has been attached to the pump, the lifting cable or elevator should be clamped to the pipe. Do not clamp the pump. When raising the pump and riser section, be careful not to place bending stress on the pump by picking it up by the pump-end only. It is recommended that plastic-type riser pipe be used only with the smaller domestic submersibles. The manufacturer or representative should be contacted to ensure the pipe type and physical characteristics are suitable for this use. Use the correct joint compound recommended by the specific pipe manufacturer. Besides making sure that points are fastened, we recommend the use of a torque arrestor when using plastic pipe.

3. Lower the Pump Into the Well

Make sure the electrical cables are not cut or damaged in any way when the pump is being lowered in the well. Do not use the power cables to support the weight of the pump.

To protect against surface water entering the well and contaminating the water source, the well should be finished off above grade utilizing a locally approved well seal or pitless adaptor unit. We recommend that steel riser pipes always be used with the larger submersibles. A pipe thread compound should be used on all joints. Make sure that the joints are adequately tightened in order to resist the tendency of the motor to loosen the joints when stopping and starting.

The drop cable should be secured to the riser pipe at approximately every 10 ft/3 m to prevent sagging, looping and possible cable damage. Nylon cable clips or waterproof tape may be used. The cable splice should be protected by securing it with clips or tape just above each joint.



Figure 2



Figure 3

IMPORTANT: Plastic pipe tends to stretch under load. This stretching must be taken into account when securing the cable to the riser pipe. Leave three to four inches of slack between clips or taped points. This tendency for plastic pipe to stretch will also affect the calculation of the pump setting depth. As a general rule, you can estimate that plastic pipe will stretch to approximately 2% of its length. When plastic riser pipe is used, it is recommended that a safety cable be attached to the pump to lower and raise it. The discharge chamber of GRUNDFOS 4-inch submersibles is designed to accommodate this cable. (See Figures 2 & 3.)

Check Valves: A check valve should always be installed at the surface of the well and one at a maximum of 25 feet above static water level. In addition, for installations deeper than 200 feet, check valves should be installed at no more than 200 foot intervals.

INSTALLATION PROCEDURES

4. Electrical Connections

WARNING: Reduced risk of electric shock during operation of this pump requires the provision of acceptable grounding. If the means of connection to the supply connected box is other than grounded metal conduit, ground the pump back to the service by connecting a copper conductor (at least the size of the circuit supplying the pump) to the grounding screw provided within the wiring compartment.

Verification of the electrical supply should be made to ensure the voltage, phase and frequency match that of the motor. Motor electrical data can be found on page 6. If voltage variations are larger than $\pm 10\%$, do not operate the pump. Single-phase motor control boxes should be connected as shown on the wiring diagram mounted on the inside cover of the control box supplied with the motor. The type of wire used between the pump control boxes should be approved for submersible pump application. The conductor insulation should be type RW, RUW, TW or equivalent.

A high-voltage surge arrestor should be used to protect the motor against lightning and switching surges. Lightning voltage surges in power lines are caused when lightning strikes somewhere in the area. Switching surges are caused by the opening and closing of switches on the main high-voltage distribution power lines.

The correct voltage-rated surge arrestor should be installed on the supply (line) side of the control box or starter (See Figure 4a & 4b). The arrestor must be grounded in accordance with the National Electric Code and local governing regulations.

PUMPS SHOULD NEVER BE STARTED UNLESS THE PUMP IS TOTALLY SUBMERGED. SEVERE DAMAGE MAY BE CAUSED TO THE PUMP AND MOTOR IF THEY ARE RUN DRY.

The control box shall be permanently grounded in accordance with the National Electric Code and local governing codes or regulations. The ground wire should be a bare stranded copper conductor at least the same size as the drop cable wire size. Ground wire should be as short a distance as possible and securely fastened to a true grounding point. True grounding points are considered to be: a grounding rod driven into the water strata; steel well casing submerged into the water lower than the pump setting level; and steel discharge pipes without insulating couplings. If plastic discharge pipe and well casing are used, a properly sized bare copper wire should be connected to a stud on the motor and run to the control panel. Do not ground to a gas supply line. Connect the grounding wire to the ground point first, then to the terminal in the control box.

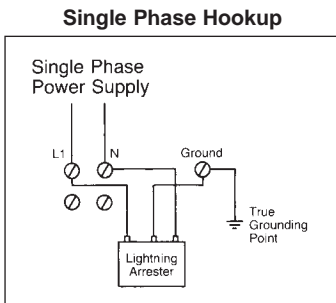

Figure 4a

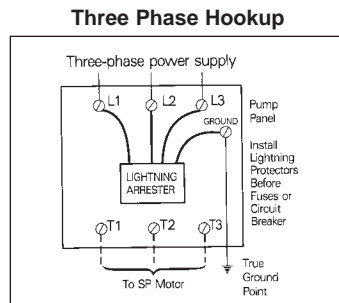
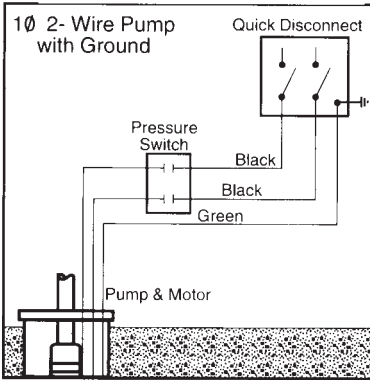

Figure 4b

INSTALLATION PROCEDURES

Single-Phase 2-Wire Wiring Diagram for Submersible Motors



Three-Phase Wiring Diagram for Submersible Motors

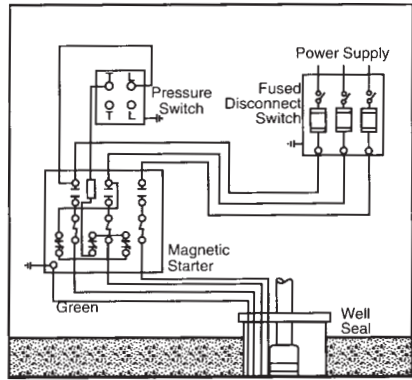

Single-Phase 3-Wire Control Box for Submersible Motors

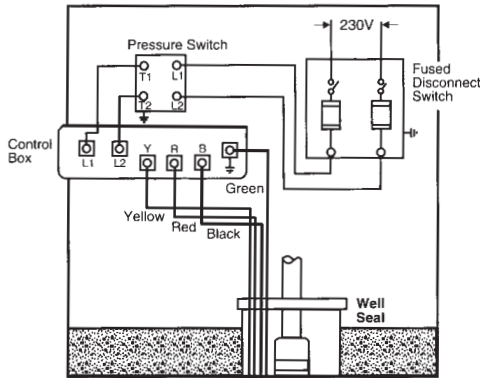

4. Starting the Pump for the First Time

- Attach a temporary horizontal length of pipe to the riser pipe.
- Install a gate valve and another short length of pipe to the temporary pipe.
- Adjust the gate valve one-third of the way open.
- Verify that the electrical connections are in accordance with the wiring diagram.
- After proper rotation has been checked, start the pump and let it operate until the water runs clear of sand, silt and other impurities.
- Slowly open the valve in small increments as the water clears until the valve is all the way open. The pump should not be stopped until the water runs clear.
- If the water is clean and clear when the pump is first started, the valve should still be opened until it is all the way open.

MOTOR INFORMATION

Grundfos motors specifications

1- Phase motors

| HP | Ph | Volt | Service factor | Amperage | | Full load | | Max. thrust (lbs) | Line-to-Line resistance () | | KVA code | Nameplate no. |
|---|----|------|----------------|----------|-------|-----------|-----------|-------------------|-----------------------------|-----------|----------|---------------|
| | | | | SF | Start | Eff. (%) | Pwr fact. | | Blk-Yel | Red-Yel | | |
| 4-inch, single phase, 2-wire motors (control box not required) | | | | | | | | | | | | |
| 1/3 | 1 | 230 | 1.75 | 4.6 | 25.7 | 59 | 77 | 900 | 6.8-8.2 | | S | 79952101 |
| 1/2 | 1 | 115 | 1.60 | 12.0 | 55 | 62 | 76 | 900 | 1.1-1.3 | | R | 79922102 |
| 1/2 | 1 | 230 | 1.60 | 6.0 | 34.5 | 62 | 76 | 900 | 5.2-6.3 | | R | 79952102 |
| 3/4 | 1 | 230 | 1.50 | 8.4 | 40.5 | 62 | 75 | 900 | 3.2-3.8 | | N | 79952103 |
| 1 | 1 | 230 | 1.40 | 9.8 | 48.4 | 63 | 82 | 900 | 2.5-3.1 | | M | 79952104 |
| 1 1/2 | 1 | 230 | 1.30 | 13.1 | 62 | 64 | 85 | 900 | 1.9-2.3 | | L | 79952105 |
| 4-inch, single phase, 3-wire motors | | | | | | | | | | | | |
| 1/3 | 1 | 115 | 1.75 | 9.0 | 29 | 59 | 77 | 900 | 1.55-1.9 | 2.4-3 | M | 79423101 |
| 1/3 | 1 | 230 | 1.75 | 4.6 | 14 | 59 | 77 | 900 | 6.8-8.3 | 17.3-21.1 | L | 79453101 |
| 1/2 | 1 | 115 | 1.60 | 12.0 | 42.5 | 61 | 76 | 900 | 0.9-1.1 | 1.9-2.35 | L | 79423102 |
| 1/2 | 1 | 230 | 1.60 | 6.0 | 21.5 | 62 | 76 | 900 | 4.7-5.7 | 15.8-19.6 | L | 79453102 |
| 3/4 | 1 | 230 | 1.50 | 8.4 | 31.4 | 62 | 75 | 900 | 3.2-3.9 | 14-17.2 | L | 79453103 |
| 1 | 1 | 230 | 1.40 | 9.8 | 37 | 63 | 82 | 900 | 2.6-3.1 | 10.3-12.5 | K | 79453104 |
| 1.5 | 1 | 230 | 1.30 | 11.6 | 45.9 | 69 | 89 | 900 | 1.9-2.3 | 7.8-9.6 | H | 79453105 |
| 2 | 1 | 230 | 1.25 | 13.2 | 57 | 72 | 86 | 1500 | 1.5-1.8 | 3.4-4.1 | G | 79454506 |
| 3 | 1 | 230 | 1.15 | 17.0 | 77 | 74 | 93 | 1500 | 1.2-1.4 | 2.45-3 | F | 79454507 |
| 5 | 1 | 230 | 1.15 | 27.5 | 110 | 77 | 92 | 1500 | 0.65-0.85 | 2.1-2.6 | F | 79454509 |

3-Phase motors

| HP | Ph | Volt | Service factor | Amperage | | Full load | | Max. thrust (lbs) | Line-to-Line resistance () | | KVA code | Nameplate no. |
|---|----|---------|----------------|-----------|--------|-----------|-----------|-------------------|-----------------------------|---------|----------|---------------|
| | | | | SF | Start. | Eff. (%) | Pwr fact. | | Blk-Yel | Red-Yel | | |
| 4-inch, three phase, 3-wire motors | | | | | | | | | | | | |
| 1 1/2 | 3 | 230 | 1.30 | 7.3 | 40.3 | 75 | 72 | 900 | 3.9 | | K | 79302005 |
| | | 460 | 1.30 | 3.7 | 20.1 | 75 | 72 | 900 | 15.9 | | K | 79362005 |
| | | 575 | 1.30 | 2.9 | 16.1 | 75 | 72 | 900 | 25.2 | | K | 79392005 |
| 3 | 3 | 230 | 1.25 | 8.7 | 48 | 76 | 75 | 900 | 3.0 | | J | 79302006 |
| | | 460 | 1.25 | 4.4 | 24 | 76 | 75 | 900 | 12.1 | | J | 79362006 |
| | | 575 | 1.25 | 3.5 | 19.2 | 76 | 75 | 900 | 18.8 | | J | 79392006 |
| 3 | 3 | 230 | 1.15 | 12.2 | 56 | 77 | 75 | 900 | 2.2 | | H | 79302006 |
| | | 460 | 1.15 | 6.1 | 28 | 77 | 75 | 900 | 9.0 | | H | 79362007 |
| | | 575 | 1.15 | 4.8 | 22 | 77 | 75 | 900 | 13.0 | | H | 79395507 |
| 5 | 3 | 208/230 | 1.15 | 18.6/17.4 | 108 | 80 | 82 | 1500 | 1.2 | | H | 79304509 |
| | | 440/460 | 1.15 | 8.65/8.65 | 54 | 80 | 82 | 1500 | 5.0 | | H | 79354509 |
| | | 575 | 1.15 | 7.9 | 54 | 80 | 82 | 1500 | 7.3 | | H | 79394509 |
| 7 1/2 | 3 | 208/230 | 1.15 | 27.0/25.0 | 130 | 81 | 82 | 1500 | 0.84 | | H | 79305511 |
| | | 440/460 | 1.15 | 12.8/12.6 | 67 | 81 | 82 | 1500 | 3.24 | | J | 79355511 |
| | | 575 | 1.15 | 10.6 | 53 | 81 | 82 | 1500 | 5.2 | | J | 79395511 |
| 10 | 3 | 440/460 | 1.15 | 18.0/18.6 | 90 | 81 | 80 | 1500 | 1.16 | | H | 79355512 |
| | | 575 | 1.15 | 14.4 | 72 | 81 | 80 | 1500 | 1.84 | | H | 79395512 |

*All Grundfos 4" motors have a ground (green wire)

GRUNDFOS Control Box SA-SPM5

| RATING | | GRUNDFOS MOTOR MODEL | GRUNDFOS CONTROL BOX | GRUNDFOS STANDARD #'s | GRUNDFOS RUN CAP/DELUXE #'s |
|--------|------|----------------------|----------------------|-----------------------|-----------------------------|
| HP | VOLT | | | | |
| 1/3 | 115 | MS402B | SA-SPM5 | 91126150 | -- |
| 1/3 | 230 | MS402B | SA-SPM5 | 91126151 | -- |
| 1/2 | 115 | MS402B | SA-SPM5 | 91126152 | -- |
| 1/2 | 230 | MS402B | SA-SPM5 | 91126153 | -- |
| 3/4 | 230 | MS402B | SA-SPM5 | 91126154 | -- |
| 1 | 230 | MS402B | SA-SPM5 | 91126155 | 91126211 |
| 1.5 | 230 | MS402B | SA-SPM5 | 91126212 | 91126213 |
| 2 | 230 | MS4000 | SA-SPM5 | 91126214 | 91126215 |
| 3 | 230 | MS4000 | SA-SPM5 | 91126216 | 91126217 |
| 5 | 230 | MS4000 | SA-SPM5 | 91126218 | 91126219 |

MOTOR INFORMATION

The key to long submersible motor life is good cooling. Most submersible pumps rely on moving heat away from the motor by forced convection. The ambient/produced fluid is typically drawn by the motor in the course of pumping to accomplish this task. Submersible motors used in the water supply industry are typically designed to operate at full load in water up to 30°C (86°F), provided the flow velocity can be maintained at a minimum of 0.5 feet per second (fps).

Required Cooling Flow and Velocity

AWWA specifications state the maximum motor diameter and the minimum inside diameter of the well shall be in such relationship that under any operating condition the water velocity past the motor shall not exceed 12 fps (3.7 m/s) nor be less than 0.5 fps (0.15 m/s). The AWWA specification are principally applicable to motors 6-inch and larger, as most 4-inch motor designs are based on a minimum cooling flow velocity of 0.25 fps (0.08 m/s) at rated ambient temperature. Table 8 relates flow, casing and motor size requirements to accomplish minimum cooling velocity.

| Table 8: Minimum Submersible Cooling Flow Requirements | | |
|---|----------------------------|---------------------------|
| Casing/Sleeve I.D. (inches) | 4" Motor (0.25 fps) | 6" Motor (0.5 fps) |
| | (gpm) | |
| 4 | 1.2 | — |
| 5 | 7.0 | — |
| 6 | 13 | 9 |
| 7 | 20 | 25 |
| 8 | 30 | 45 |
| 10 | 50 | 90 |
| 12 | 80 | 140 |
| 14 | 110 | 200 |
| 16 | 150 | 280 |
| 18 | — | 380 |

Notes: 1. Minor irregularities associated with motor shape and diameter variations between manufactures are not accounted for in the table.
 2. At the velocity specified in the table the temperature differential between the motor surface and ambient water will range from 5° - 15°C (10-30°F).

Some submersible motor manufactures require no cooling fluid flow past the motor, when the produced fluid temperature is 20°C (68°F) or less. Cooling by free convection in such cases, is only permitted in the vertical position and is contingent on no adverse operating conditions present such as; poor power, high stop/start frequency, presence of incrustating deposits on the motor surface, etc. Detrimental operating conditions are difficult to identify or predict, and for this reason, the minimum cooling flow should be provided whenever possible - regardless of the ambient fluid temperature.

MOTOR INFORMATION

Typical Motor Jacket/Shroud Configurations.

The motor shroud is generally of the next nominal diameter of standard pipe larger than the motor or the pump, depending on the shroud configuration used. The tubular/pipe material can be plastic or thin walled steel (corrosion resistant materials preferred). The cap/top must accommodate power cable without damage and provide a snug fit, so that only a very small amount of fluid can be pulled through the top of the shroud. The fit should not be completely water tight as ventilation is often required to allow escape of the air or gas that might accumulate. The shroud body should be stabilized to prevent rotation and maintain the motor centered within the shroud. The shroud length should extend to a length of 1-2 times the shroud diameter beyond the bottom of the motor when possible. Shrouds are typically attached immediately above the pump intake or at the pump/column correction.

A typical motor sleeve/shroud selection example is sited below and illustrated in Figure 8:

If a well feeds water from above the pump, has a casing/chamber too small to allow a motor jacket/sleeve on the pump, and does not have adequate level and flow to allow raising the pump above the inflow, it is difficult to properly cool the motor. When possible, the casing depth should be increased to allow flow to come from below the motor. If this is not practical, adequate flow past the motor can usually be attained by employing a motor jacket with a stringer pipe or by using a jet tube.

Figure 8: Typical Motor Jacket Installation Scenarios

Typical Flow Inducer Sleeve Cutaway View

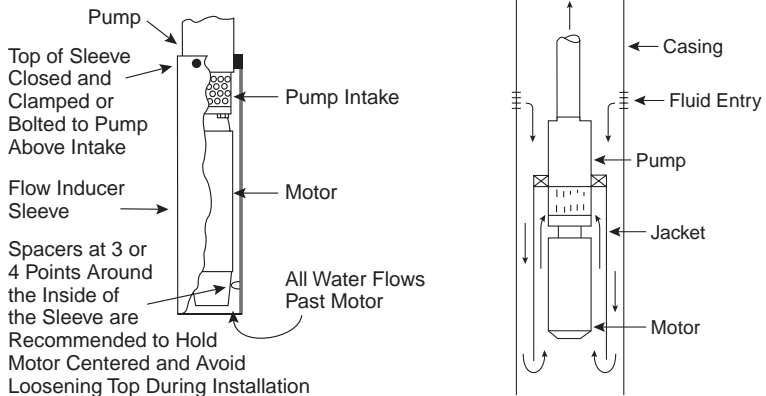

MOTOR INFORMATION

Single-Phase 60 Hz

| MOTOR RATING | | COPPER WIRE SIZE (AWG) | | | | | | | | |
|--------------|-------|------------------------|-----|------|------|------|------|------|------|------|
| VOLTS | HP | 14 | 12 | 10 | 8 | 6 | 4 | 2 | 0 | 00 |
| 115 | 1/3 | 130 | 210 | 340 | 540 | 840 | 1300 | 1960 | 2910 | |
| | 1/2 | 100 | 160 | 250 | 390 | 620 | 960 | 1460 | 2160 | |
| 230 | 1/3 | 550 | 880 | 1390 | 2190 | 3400 | 5250 | 7960 | | |
| | 1/2 | 400 | 650 | 1020 | 1610 | 2510 | 3880 | 5880 | | |
| | 3/4 | 300 | 480 | 760 | 1200 | 1870 | 2890 | 4370 | 6470 | |
| | 1 | 250 | 400 | 630 | 990 | 1540 | 2380 | 3610 | 5360 | 6520 |
| | 1-1/2 | 190 | 310 | 480 | 770 | 1200 | 1870 | 2850 | 4280 | 5240 |
| | 2 | 150 | 250 | 390 | 620 | 970 | 1530 | 2360 | 3620 | 4480 |
| | 3 | 120 | 190 | 300 | 470 | 750 | 1190 | 1850 | 2890 | 3610 |
| | 5 | 180 | 280 | 450 | 710 | 1110 | 1740 | 2170 | | |

Three-Phase 60 Hz

| MOTOR RATING | | COPPER WIRE SIZE (AWG) | | | | | | | |
|--------------|-------|------------------------|------|------|------|------|------|------|------|
| VOLTS | HP | 14 | 12 | 10 | 8 | 6 | 4 | 2 | |
| 208 | 1-1/2 | 310 | 500 | 790 | 1260 | | | | |
| | 2 | 240 | 390 | 610 | 970 | 1520 | | | |
| | 3 | 180 | 290 | 470 | 740 | 1160 | 1810 | | |
| | | 5170 | 280 | 4690 | 1080 | | | | 1660 |
| 230 | 1-1/2 | 360 | 580 | 920 | 1450 | | | | |
| | 2 | 280 | 450 | 700 | 1110 | 1740 | | | |
| | 3 | 210 | 340 | 540 | 860 | 1340 | 2080 | | |
| | | 5 | 200 | 320 | 510 | 800 | 1240 | 1900 | |
| 460 | 1-1/2 | 1700 | | | | | | | |
| | 2 | 1300 | 2070 | | | | | | |
| | 3 | 1000 | 1600 | 2520 | | | | | |
| | | 5 | 590 | 950 | 1500 | 2360 | | | |
| 575 | 1-1/2 | 2620 | | | | | | | |
| | 2 | 2030 | | | | | | | |
| | 3 | 1580 | 2530 | | | | | | |
| | | 5 | 920 | 1480 | 2330 | | | | |

FOOTNOTES:

1. If aluminum conductor is used, multiply lengths by 0.5. Maximum allowable length of aluminum is considerably shorter than copper wire of same size.
2. The portion of the total cable which is between the service entrance and a 3Ø motor starter should not exceed 25% of the total maximum length to ensure reliable starter operation. Single-phase control boxes may be connected at any point of the total cable length.
3. Cables #14 to #0000 are AWG sizes, and 250 to 300 are MCM sizes.

TROUBLESHOOTING

SUPPLY VOLTAGE

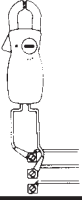

How to Measure

By means of a voltmeter, which has been set to the proper scale, measure the voltage at the control box or starter. On single-phase units, measure between line and neutral.

What it Means

When the motor is under load, the voltage should be within $\pm 10\%$ of the nameplate voltage. Larger voltage variation may cause winding damage. Large variations in the voltage indicate a poor electrical supply and the pump should not be operated until these variations have been corrected.

If the voltage constantly remains high or low, the motor should be changed to the correct supply voltage.

CURRENT MEASUREMENT

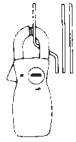

How to Measure

By use of an ammeter, set on the proper scale, measure the current on each power lead at the control box. See page 6, for motor amp draw information.

Current should be measured when the pump is operating at a constant discharge pressure with the motor fully loaded.

What it Means

If the amp draw exceeds the listed service factor amps (SFA), check for the following:

1. Loose terminals in control box or possible cable defect. Check winding and insulation resistances.
2. Too high or low supply voltage.
3. Motor windings are shorted.
4. Pump is damaged causing a motor overload.

WINDING RESISTANCE

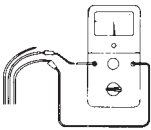

How to Measure

Turn off power and disconnect the drop cable leads in the control box. Using an ohmmeter, set the scale selectors to Rx1 for values under 10 ohms and Rx10 for values over 10 ohms.

Zero-adjust the meter and measure the resistance between leads. Record the values. Motor resistance values can be found on page 6.

What it Means

If all the ohm values are normal, and the cable colors correct, the windings are not damaged. If any one ohm value is less than normal, the motor may be shorted. If any one ohm value is greater than normal, there is a poor cable connection or joint. The windings or cable may also be open.

If some of the ohm values are greater than normal and some less, the drop cable leads are mixed. To verify lead colors, see resistance values on page 6.

INSULATION RESISTANCE

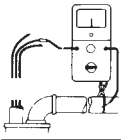

How to Measure

Turn off power and disconnect the drop cable leads in the control box. Using an ohm or mega ohmmeter, set the scale selector to Rx 100K and zero-adjust the meter. Measure the resistance between the lead and ground (discharge pipe or well casing, if steel).

What it Means

For ohm values, refer to table below. Motors of all Hp, voltage, phase and cycle duties have the same value of insulation resistance.

| OHM VALUE | MEGAOHM VALUE | CONDITION OF MOTOR AND LEADS |
|---------------------|---------------|--|
| 2,000,000 (or more) | 2.0 | Motor not yet installed: New Motor. |
| 1,000,000 (or more) | 1.0 | Used motor which can be reinstalled in the well. |
| 500,000 - 1,000,000 | 0.5 - 1.0 | Motor in well (Ohm readings are for drop cable plus motor): A motor in reasonably good condition. |
| 20,000 - 500,000 | 0.02 - 0.5 | A motor which may have been damaged by lightning or with damaged leads. Do not pull the pump for this reason. |
| 10,000 - 20,000 | 0.01 - 0.02 | A motor which definitely has been damaged or with damaged cable. The pump should be pulled and repairs made to the cable or the motor replaced. The motor will still operate, but probably not for long. |
| less than 10,000 | 0 - 0.01 | A motor which has failed or with completely destroyed cable insulation. The pump must be pulled and the cable repaired or the motor replaced. The motor will not run in this condition. |

TROUBLESHOOTING

Pump Won't Start

| POSSIBLE CAUSE | CHECK THIS BY... | CORRECT THIS BY... |
|---|--|---|
| No power at the motor | Check for voltage at the control box or panel. | If there is no voltage at the control panel, check the feeder panel for tripped circuits and reset those circuits. |
| Fuses are blown or the circuit breakers have tripped | Turn off the power and remove the fuses. Check for continuity with an ohmmeter. | Replace the blown fuses or reset the circuit breaker. If the new fuses blow or the circuit breaker trips, the electrical installation, motor, and wires must be checked for defects. |
| (3-phase motors only) Motor starter overloads are burned or have tripped | Check for voltage on the line and load side of the starter. Check the amp draw and make sure the heater is sized correctly. | Replace any burned heaters or reset. Inspect the starter for other damage. If the heater trips again, check the supply voltage. Ensure that heaters are sized correctly and the trip setting is appropriately adjusted. |
| (3-phase motors only) Starter does not energize | Energize the control circuit and check for voltage at the holding coil. | If there is no voltage, check the control circuit fuses. If there is voltage, check the holding coil for weak connections. Ensure that the holding coil is designed to operate with the available control voltage. Replace the coil if defects are found. |
| Defective controls | Check all safety and pressure switches for defects. Inspect the contacts in control devices. | Replace worn or defective parts or controls. |
| Motor or cable is defective | Turn off the power and disconnect the motor leads from the control box. Measure the lead-to-lead resistance with an ohmmeter (set to R x 1). Measure the lead-to-ground values with an ohmmeter (set to R x 100K). | If an open or grounded winding is found, remove the motor from the well and recheck the measurements with the lead separated from the motor. Repair or replace the motor or cable. |
| (1-phase motors only) Defective capacitor | Turn off the power and discharge the capacitor by shorting the leads together. Check it with an analog ohmmeter (set to R x 100k). | When the meter is connected to the capacitor, the needle should jump toward 0 (zero) ohms and slowly drift back to infinity (∞). Replace capacitor if it is defective. |
| Defective pressure switch or the tubing to it is plugged | Watch the pressure gauges as the pressure switch operates. Remove the tubing and blow through it. | Replace as necessary. |
| The pump is mechanically bound or stuck | Turn off the power and manually rotate the pump shaft. Also check the motor shaft rotation, the shaft height, and the motor's amp draw (to see if it indicates a locked rotor). | If the pump shaft doesn't rotate, remove the pump and examine it. If necessary, dismantle it and check the impellers and seal for obstruction. Check for motor corrosion. |

Pump Does Not Produce Enough Flow (GPM)

| POSSIBLE CAUSE | CHECK THIS BY... | CORRECT THIS BY... |
|--|--|--|
| (3-phase motors only) Shaft is turning in the wrong direction | Check to make sure the electrical connections in the control panel are correct. | Correct the wiring. For single phase motors, check the wiring diagram on the motor. For three phase motors, simply switch any two power leads. |
| Pump is operating at the wrong speed (too slow) | Check for low voltage and phase imbalance. | Replace defective parts or contact power company, as applicable. |
| Check valve is stuck (or installed backwards) | Remove the check valve. | Re-install or replace. |
| Parts or fittings in the pump are worn – or – Impellers or Inlet Strainer is clogged | Install a pressure gauge near the discharge port, start the pump, and gradually close the discharge valve. Read the pressure at shutoff. (Do not allow the pump to operate for an extended period at shutoff.) | Convert the PSI you read on the gauge to Feet of Head by: $\text{PSI} \times 2.31 \text{ ft/PSI} = \text{_____ ft.}$ <p style="text-align: center;">Specific Gravity</p> Add to this number the number of feet (vertically) from the gauge down to the water's pumping level. Refer to the pump curve for the model you are working with to determine the shutoff head you should expect for that model. If that head is close to the figure you came up with (above), the pump is probably OK. If not, remove the pump and inspect impellers, chambers, etc. |
| The water level in the well may be too low to supply the flow desired – or – Collapsed well | Check the drawdown in the well while the pump is operating. | If the pumping water level (including drawdown) is not AT LEAST 3 FEET above the pump's inlet strainer, either: 1. Lower the pump further down the well. 2. Throttle back the discharge valve to decrease the flow, thereby reducing drawdown. |
| Broken shaft or coupling | Pull pump and inspect. | Replace as necessary. |
| There are leaks in the fittings or piping | Pull the pump out of the well. | The suction pipe, valves, and fittings must be made tight. Repair any leaks and retighten all loose fittings. |

TROUBLESHOOTING

Fuses Blow or Heaters Trip

| POSSIBLE CAUSE | CHECK THIS BY... | CORRECT THIS BY... |
|--|--|--|
| Improper voltage | Check the voltage at the control box or panel. | If the voltage varies by more than 10% (+ or -), contact the power company. |
| | If the incoming voltage is OK, check the wire size and the distance between the pump motor and the pump control panel. | Rewire with correct gauge. Undersized wire and a great distance between the control panel and the pump motor increases resistance and decreases the voltage by the time it reaches the pump motor. |
| The starter overloads are set too low | Cycle the pump and measure the amperage. | Increase the heater size or adjust the trip setting. Do not, however, exceed the recommended rating. |
| (3-phase motors only) The three-phase current is imbalanced | Check the current draw on each lead to the motor. | The current draw on each lead must be within 5% of each other (+ or -). If they are not, check the wiring. |
| The wiring or connections are faulty | Check to make sure the wiring is correct and there are no loose terminals. | Tighten any loose terminals and replace any damaged wire. |
| (1-phase motors only) Capacitor is defective | Turn off the power and discharge the capacitor. Check the capacitor with an ohmmeter (set at R x 100k). See page 15 for instructions. | When the meter is connected to the capacitor, the needle should jump toward 0 (zero) ohms and then slowly drift back to infinity (∞). Replace capacitor if it is defective. |
| Fuse, heater, or starter are the wrong size | Check the fuses and heaters against the motor manufacturer's specification charts. | Replace as necessary. |
| The control box location is too hot | Touch the box with your bare hand during the hottest part of the day – you should be able to keep your hand on it without burning. | Shade, ventilate, or move the control box so its environment does not exceed 120°F. |
| (1-phase motors only) Wrong control box | Check requirements for the motor against the control box specifications. | Replace as necessary. |
| Defective pressure switch | Watch gauges as pressure switch operates. | Replace as necessary. |
| The motor is shorted or grounded. | Turn off the power and disconnect the wiring. Measure the lead-to-lead resistance with an ohmmeter (set to R x 1). Measure the lead-to-ground values with an ohmmeter (set to R x 100K) or a megohmmeter. Compare these measurements to the rated values for your motor. | If you find an open or grounded winding, remove the motor and recheck the leads. If OK, check the leads for continuity and for bad splice. |
| Poor motor cooling | Find the internal diameter of the well casing (or sleeve, if used). For proper cooling, the flow of water must not be less than the GPM shown across the bottom scale on page ___ . | Throttle up the pump flow (GPM) so proper cooling is possible. – or – Pull the pump out of the well and add a sleeve with a smaller internal diameter. |

Pump Cycles Too Often

| POSSIBLE CAUSE | CHECK THIS BY... | CORRECT THIS BY... |
|--|---|---|
| The pressure switch is defective or is not properly adjusted | Check the pressure setting on the switch. Check the voltage across closed contacts. | Readjust the pressure switch or replace it if defective. |
| The tank is too small | Check the tank size and amount of air in the tank. The tank volume should be approximately 10 gallons for each Gallon-Per-Minute of pump capacity. At the pump cut-in pressure, the tank should be about 2/3 filled with air. | Replace the tank with one that is the correct size. |
| There is insufficient air charging of the tank or piping is leaking | Pump air into the tank or diaphragm chamber. Check the diaphragm for leaks. Check the tank and piping for leaks with soapy water. Check the air-to-water ratio in the tank. | Repair as necessary. |
| Plugged snifter valve or bleed orifice (causing pressure tank to be waterlogged) | Examine them for dirt or erosion. | Repair or replace as necessary. |
| Leak in the pressure tank or piping | Apply soapy water to pipes and tank, then watch for bubbles, indicating leaks. | Repair or replace as necessary. |
| The level control is defective or is not properly set | Check the setting and operation of the level control. | Readjust the level control setting (according to the manufacturer's instructions) or replace it if defective. |
| Pump is oversized for the application. It is outpumping the yield of the well and pumping itself dry. | Check the yield of the well (determined by the well-test) against the pump's performance curve. | Reduce the flow by throttling back the valve. – or – Change the pump. |

LIMITED WARRANTY

Products manufactured by GRUNDFOS are warranted to the original user only to be free of defects in material and workmanship for a period of 24 months from date of installation, but not more than 30 months from date of manufacture. GRUNDFOS' liability under this warranty shall be limited to repairing or replacing at GRUNDFOS' option, without charge, F.O.B. GRUNDFOS' factory or authorized service station, any product of GRUNDFOS' manufacture. GRUNDFOS will not be liable for any costs of removal, installation, transportation, or any other charges which may arise in connection with a warranty claim. Products which are sold but not manufactured by GRUNDFOS are subject to the warranty provided by the manufacturer of said products and not by GRUNDFOS' warranty. GRUNDFOS will not be liable for damage or wear to products caused by abnormal operating conditions, accident, abuse, misuse, unauthorized alteration or repair, or if the product was not installed in accordance with GRUNDFOS printed installation and operating instructions.

To obtain service under this warranty, the defective product must be returned to the distributor or dealer of GRUNDFOS products from which it was purchased together with proof of purchase and installation date, failure date, and supporting installation data. Unless otherwise provided, the distributor or dealer will contact GRUNDFOS or an authorized service station for instructions. Any defective product to be returned to GRUNDFOS or a service station must be sent freight prepaid; documentation supporting the warranty claim and/or a Return Material Authorization must be included if so instructed.

MANUFACTURER WILL NOT BE LIABLE FOR ANY INCIDENTAL OR CONSEQUENTIAL DAMAGES, LOSSES, OR EXPENSES ARISING FROM INSTALLATION, USE, OR ANY OTHER CAUSES. THERE ARE NO EXPRESS OR IMPLIED WARRANTIES, INCLUDING MERCHANTABILITY OR FITNESS FOR A PARTICULAR PURPOSE, WHICH EXTEND BEYOND THOSE WARRANTIES DESCRIBED OR REFERRED TO ABOVE. EXCEPT AS EXPRESSLY HEREIN PROVIDED THE GOODS ARE SOLD "AS IS", THE ENTIRE RISK AS TO QUALITY AND FITNESS FOR A PARTICULAR PURPOSE, AND PERFORMANCE OF THE GOODS IS WITH THE BUYER, AND SHOULD THE GOODS PROVE DEFECTIVE FOLLOWING THEIR PURCHASE, THE BUYER AND NOT THE MANUFACTURER, DISTRIBUTOR, OR RETAILER ASSUMES THE ENTIRE RISK OF ALL NECESSARY SERVICING OR REPAIR.

Some jurisdictions do not allow the exclusion or limitation of implied warranties of merchantability and fitness for a particular purpose, of incidental or consequential damages and some jurisdictions do not allow limitations on how long implied warranties may last or require you to pay certain expenses as set forth above. Therefore, the above limitations or exclusions may not apply to you. This warranty gives you specific legal rights and you may also have other rights which vary from jurisdiction to jurisdiction.

U.S.A.

Grundfos Pumps Corporation
17100 W. 118th Terrace
Olathe, KS 66061
Telephone (913) 227-3400
Fax: (913) 227-3500

Canada

Grundfos Canada, Inc.
2941 Brighton Road
Oakville, Ontario L6H 6C9, Canada
Telephone: (905) 829-9533
Fax: (905) 829-9512

Mexico

Bombas Grundfos de Mexico, S.A. de C.V.
Boulevard TLC No. 15
Parque Industrial Stiva Aeropuerto
Apodaca, N.L. Mexico
C.P. 66600 Apodaca, N.L. Mexico
Telephone: 011-52-81-8144-4000
Fax: 011-52-81-8144-4010

L-SP-TL-048 Rev. 5/08(US)