

# Myers®

Pentair Pump Group

## Installation and Service Instructions Centri-Thrift Pumps CT Series

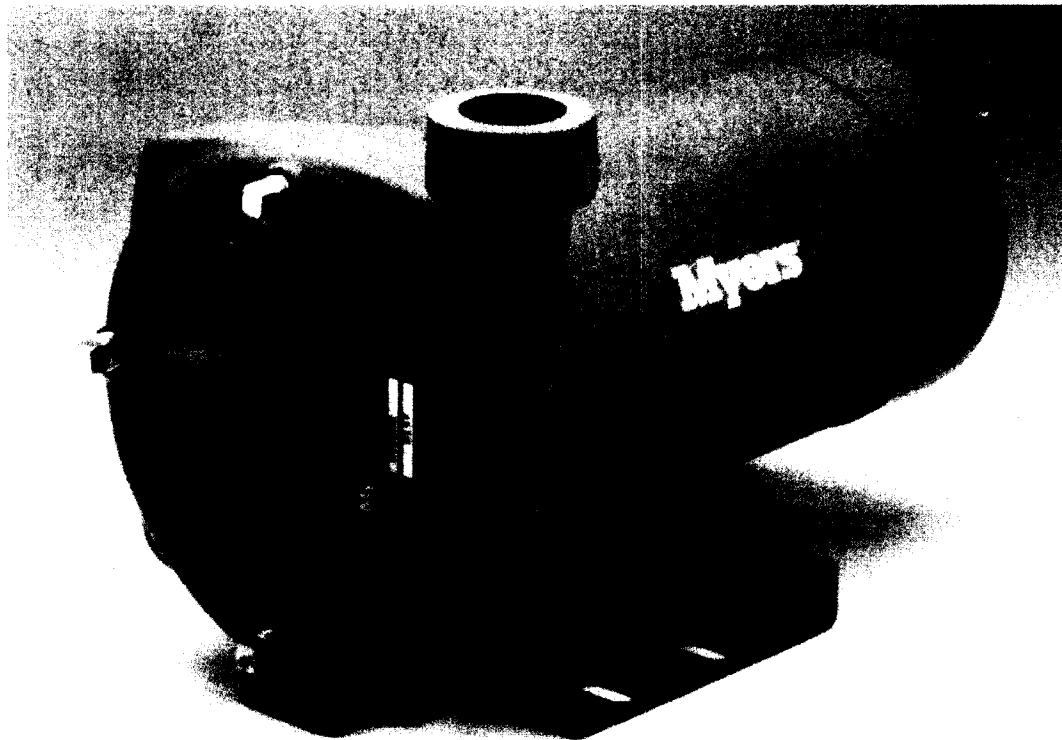

**WARNING! IMPORTANT SAFETY INSTRUCTIONS! READ CAREFULLY BEFORE INSTALLATION**



**FAILURE TO FOLLOW THESE INSTRUCTIONS AND COMPLY WITH ALL CODES MAY CAUSE SERIOUS BODILY INJURY AND/OR PROPERTY DAMAGE**

**BE CERTAIN THE PUMP POWER SOURCE IS TURNED OFF AND DISCONNECTED.**

⚠ 2) All installation and electrical wiring must adhere to state and local codes. Check with appropriate community agencies, or contact your local electrical and pump professionals for help.

⚠ 3) CALL AN ELECTRICIAN WHEN IN DOUBT. Pump must be connected to a separate electrical circuit directly from the entrance box. There must be an appropriately sized fuse or circuit breaker in this line. Tying into existing circuits may cause circuit overloading, blown fuses, tripped circuit breakers, or a burned up motor.

⚠ 4) Do not connect pump to a power supply until the pump is grounded. For maximum safety, a ground fault interrupter should be used. **CAUTION: FAILURE TO GROUND THIS UNIT PROPERLY MAY RESULT IN SEVERE ELECTRICAL SHOCK.**

⚠ 5) **WARNING:** Reduced risk of electric shock during operation of this pump requires the provision of acceptable grounding if the means of connection to the supply-connection box is other than grounded metal conduit, ground the motor back to the service by connecting a copper conductor, at least the size of the circuit conductors supplying the motor, to the ground screw provided within the wiring compartment of the motor.

⚠ 6) The voltage and phase of the power supply must match the voltage and phase of the pump motor.

⚠ 7) Do not use an extension cord.

⚠ 8) Do not work on this pump or switch while the power is on.

⚠ 9) Never operate a pump with a frayed or brittle power cord, and always protect it from sharp objects, hot surfaces, oil and chemicals. Avoid kinking the cord.

⚠ 10) Never service a motor or power cord with wet hands or while standing in or near water or damp ground.

⚠ 11) The three phase units must be wired by a qualified electrician, using an approved starter box and switching device.

⚠ 12) Do not use this pump in or near a swimming pool, pond, lake or river.

⚠ 13) Single phase motors are equipped with automatic resetting thermal protectors. The motor may restart unexpectedly causing the leads to energize or pump to turn. Three phase motors should be protected by proper, thermal and amperage protection. (Check local codes.)

⚠ 14) Do not pump gasoline, chemicals, corrosives, or flammable liquids; they could ignite, explode, or damage the pump, causing injury and voiding the warranty.

⚠ 15) Do not run this pump with the discharge completely closed this will create superheated water, which could damage the seal, and shorten the life of the motor. This superheated water could also cause severe burns.

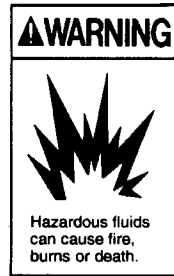

⚠ 16) The following may cause severe damage to the pump and void warranty. It could also result in personal injury:

- Running the pump dry.
- Failure to protect the pump from below freezing temperatures.
- Running the pump with the discharge completely closed.
- Pumping chemicals or corrosive liquids.

⚠ 17) Never work on the pump or system without relieving the internal pressure.

⚠ 18) Do not pump water above 120° Fahrenheit.

⚠ 19) Never exceed the pressure rating of any system component.

## INSTALLATION

**PACKAGE CONTENTS** - 1. Each pump is carefully tested and packaged at the factory.  
2. The catalog lists all parts included with package. A packing list packed with pump, also lists contents.  
3. Be sure all parts have been furnished and that nothing has been damaged in shipment.  
4. **OPEN PACKAGES AND MAKE THIS CHECK BEFORE GOING ON JOB.**

**PIPING** - Pipes must line up and not be forced into position by unions. **Piping should be independently supported near the pump so that no strain will be placed on the pump casing.** Where any noise is objectionable, pump should be insulated from the piping with rubber connections. Always keep pipe size as large as possible and use a minimum of fittings to reduce friction losses.

**SUCTION PIPING** - Suction pipe should be direct and as short as possible. It should be at least one size larger than suction inlet tapping and should have a minimum of elbows and fittings. The piping should be laid out so that it slopes upward to pump without dips or high points so that air pockets are eliminated. The highest point in the suction piping should be the pump inlet except where liquid flows to the pump inlet under pressure. A foot valve must be used to keep pump primed. Where liquid flows to the pump, it may be desirable to use a check valve in the suction line or discharge line to keep pump primed.

To prevent air from being drawn into suction pipe due to a suction whirlpool, the foot valve should be submerged at least three feet below the low water level. The suction pipe must be tight and free of air leaks or pump will not operate properly.

**DISCHARGE PIPING** - Discharge piping should never be smaller than pump tapping and should preferably be one size larger. A gate valve should always be installed in discharge line for throttling if capacity is not correct. To protect the pump from water hammer and to prevent backflow, a check valve should be installed in the discharge line between the pump and gate valve.

**ELECTRICAL CONNECTIONS** - Be sure motor wiring is connected for voltage being used. Unit should be connected to a separate circuit, direct from main switch. A fused disconnect switch or circuit breaker must be used in this circuit. Wire of sufficient size should be used to keep voltage drop to a maximum of 5%. All motors, unless provided with built-in overload protection, must be protected with

an overload switch, either manual or magnetic. Single phase ½-2½ HP motors have built-in overload protection. **Never install a pump without proper overload protection.** When motor is mounted on a base plate or on slide rails for adjustment, flexible metallic conduit should be used to protect the motor leads.

**PRIMING** - The pump must be primed before starting. The pump casing and suction piping must be filled with water before starting motor. Remove vent plug in top of casing while pouring in priming water. A hand pump or ejector can be used for priming when desired. When water is poured into pump to prime, use care to remove all air before starting motor.

If pump does not start immediately, stop and reprime.

**STARTING** - It is good practice to close the discharge valve when starting the pump as it puts less starting load on the motor. When the pump is up to operating speed, open the discharge valve to obtain desired capacity or pressure. Do not allow the pump to run for long periods with the discharge valve tightly closed. If the pump runs for an extended period of time without liquid being discharged, the liquid in the pump case can get extremely hot.

**ROTATION** - The pump must run in direction of arrow on pump case. All single phase motors are single rotation and leave factory with proper rotation. Three phase motors may run either direction. If rotation is wrong when first starting motor, interchange any two line leads to change rotation.

**STOPPING** - Before stopping pump, close the discharge valve. This will prevent water hammer and is especially important on high head pumps.

**FREEZING** - Care should be taken to prevent the pump from freezing during cold weather. It may be necessary, when there is any possibility of this, to drain the pump casing when not in operation. Drain by removing the pipe plug in the bottom of the casing.

**ROTARY SEAL** - Centri-Thrift pumps are fitted only with a rotary seal. This seal is recommended for water free from abrasives. If liquid contains abrasives, the Centri-Thrift pump should not be used.

**BEARINGS** - The pump motor uses sealed ball bearings that are factory lubricated and require not further lubrication.

## **DISASSEMBLY INSTRUCTIONS**

All pumping parts can be removed from case without disturbing the piping.

**POWER SUPPLY** - Open the power supply switch contacts and remove fuses. Disconnect the electrical wiring from the motor.

### **VOLUTE CASE**

- (a) Drain pump case by removing drain plug.
- (b) Remove the cap screws securing volute case to pump bracket.
- (c) Pry volute case from seal plate with a screwdriver.

### **IMPELLER**

- (a) Remove motor end cover.
- (b) Loosen clamp holding start capacitor and swing capacitor off to one side, do not disconnect wires.
- (c) Wrench flats are on the shaft just behind the centrifugal switch that is screwed into the end of the shaft. Do not remove this switch. A 7/16" open end wrench can then be used to hold the shaft from turning.
- (d) Grasp the impeller and turn counterclockwise (as viewed from the pump end).

### **SEAL**

- (a) Remove the rotating part of the seal by pulling it off the shaft.
- (b) The stationary seat can be pressed from the seal plate.

## **ASSEMBLY INSTRUCTIONS**

All pump parts should be cleaned thoroughly before being reassembled.

### **MOTOR**

- (a) Assure that the rubber slinger is in place on the motor shaft.

### **SEAL**

- (a) A new pump seal should always be used when rebuilding a pump.

- (b) Apply some light oil to the rubber which surrounds the ceramic stationary seat. Insert the seal seat into the seal plate using finger pressure to press firmly and squarely until it bottoms. Care must be taken to keep grease and dirt off face areas of the seal. Be sure the seal faces are not damaged during assembly (cracked, scratched, or chipped) or the seal will leak.
- (c) Position the seal plate into the motor flange. use care not to chip the stationary seal seat by hitting the motor shaft.
- (d) By hand, carefully press the rotating seal assembly onto the motor shaft. The smooth face of the carbon ring must contact the ceramic seat. The rubber ring must seal against the shaft.

### **IMPELLER**

- (a) Hold the motor shaft with a 7/16" open end wrench.
- (b) Check that the rubber ring of the seal is positioned on the shaft.
- (c) Turn the impeller clockwise onto the shaft.
- (d) Replace the capacitor taking care not to pinch any wires and tighten capacitor clamp.
- (e) Replace motor end cover taking care not to pinch any wires.

### **VOLUTE**

- (a) Assure that a new or good condition gasket is in place on the seal plate.
- (b) Carefully position the volute in alignment over the impeller and seal plate.
- (c) Assemble the components with four 3/8-16UNC cap screws. The bottom two cap screws must also pass through the bracket.

### **RESTARTING OPERATION**

- (a) The pump must be primed before starting. The pump volute and suction piping must be filled with water before starting motor. A hand pump or ejector can be used for priming when desired.
- (b) Reconnect electric power.
- (c) After a few minutes of operation, check that there is no leakage from the pump or piping.

**PARTS LIST**  
**CENTRI-THRIFT CT SERIES**  
**½, ¾, 1, 1½ HP**

ITEM NO.	DESCRIPTION	QUANTITY REQUIRED	PART NUMBER
1	Motor		
	1/2 HP, 115/230V, 1 Phase	1	26452A000
	1/2 HP, 208-230/460V, 3 Phase	1	26452A001
	¾ HP, 115/230V, 1 Phase	1	26453A000
	¾ HP, 208-230/460V, 3 Phase	1	26453A001
	1 HP, 115/230V, 1 Phase	1	26454A000
	1 HP, 208-230/460V, 3 Phase	1	26454A001
	1-1/2 HP, 115/230V, 1 Phase	1	26455A000
	1-1/2 HP, 208-230/460V, 3 Phase	1	26455A001
3	Seal, Rotary 5/8 Shaft		
	Standard Seal with Polycarbonate Impeller	1	14525A010
	Hi-Temp Seal with Brass Impeller	1	21181A021
4	Plate, Seal - Cast Iron	1	26442C000
5	Case, Volute - Cast Iron		
	BSPP Threads	1	26443D000
	NPT Threads	1	26443D001
6	Impeller		
	Polycarbonate, 1/2 HP, 1 Phase	1	26441B003
	Polycarbonate, 1/2 HP, 3 Phase	1	26441B005
	Polycarbonate, ¾ HP, 1 Phase	1	26440B003
	Polycarbonate, ¾ HP, 3 Phase	1	26440B005
	Polycarbonate, 1 HP, 1 Phase	1	26439B007
	Polycarbonate, 1 HP, 3 Phase	1	26439B011
	Polycarbonate, 1-1/2 HP, 1 Phase	1	26439B004
	Polycarbonate, 1-1/2 HP, 3 Phase	1	26439B010
	Bronze, 1/2 HP, 1 Phase	1	26441B000
	Bronze, 1/2 HP, 3 Phase	1	26441B004
	Bronze, ¾ HP, 1 Phase	1	26440B000
	Bronze, ¾ HP, 3 Phase	1	26440B004
	Bronze, 1 HP, 1 Phase	1	26439B001
	Bronze, 1 HP, 3 Phase	1	26439B009
	Bronze, 1-1/2 HP, 1 Phase	1	26439B000
	Bronze, 1-1/2 HP, 3 Phase	1	26439B008
	7	Tube	1
8	Bracket	1	25383B002
9	Cap Screw, 3/8-16 UNC x 1 1/8 Lg.	4	19101A016
11	Gasket, 6-3/8 x 5-19/32 x 1/32 Vellumoid	1	05059A446
12	Plug, 1/8 NPT - Galvanized	3	05022A021
13	Plate, Name	1	17908A000
26	Cap Screw, 1/4-28 UNF x 7/8 Lg. (3 Phase)	1	19099A032
27	Washer, 11/16 O.D. Bronze (3 Phase)	1	10186A000

**PARTS LIST**  
**CENTRI-THRIFT CT SERIES**  
**2 and 2½ HP**

ITEM NO.	DESCRIPTION	QUANTITY REQUIRED	PART NUMBER
1	Motor		
	2 HP, 115/230V, 1 Phase	1	26489A000
	2 HP, 208-230/460V, 3 Phase	1	26489A001
	2-1/2 HP, 115/230V, 1 Phase	1	26490A000
	2-1/2 HP, 208-230/460V, 3 Phase	1	26490A001
3	Seal, Rotary 5/8 Shaft		
	Standard Seal with Polycarbonate Impeller	1	14525A010
	Hi-Temp Seal with Brass Impeller	1	21181A021
4	Plate, Seal - Cast Iron	1	26485D000
5	Case, Volute - Cast Iron		
	2 HP - BSPP Threads	1	26484D001
	2 HP - NPT Threads	1	26484D003
	2-1/2 HP - BSPP Threads	1	26484D000
	2-1/2 HP - NPT Threads	1	26484D002
6	Impeller		
	Polycarbonate, 2 HP, 1 Phase	1	26487C005
	Polycarbonate, 2 HP, 3 Phase	1	26487C009
	Polycarbonate, 2-1/2 HP, 1 Phase	1	26487C004
	Polycarbonate, 2-1/2 HP, 3 Phase	1	26487C008
	Bronze, 2 HP, 1 Phase	1	26487C001
	Bronze, 2 HP, 3 Phase	1	26487C007
	Bronze, 2-1/2 HP, 1 Phase	1	26487C000
Bronze, 2-1/2 HP, 3 Phase	1	26487C006	
7	Tube	1	26238A000
8	Bracket	1	26488C000
9	Cap Screw, 3/8-16 UNC x 1-1/8 Lg.	4	19101A016
11	Gasket, 6.58 x 6.13, Vellumoid	1	05059A447
12	Plug, 1/8 NPT - Galvanized	3	05022A021
13	Plate, Name	1	17908A000
26	Cap Screw, 1/4-28 UNF x 1-1/8 Lg. (3 Phase)	1	19099A031
27	Washer, 11/16 O.D. Bronze (3 Phase)	1	10186A000

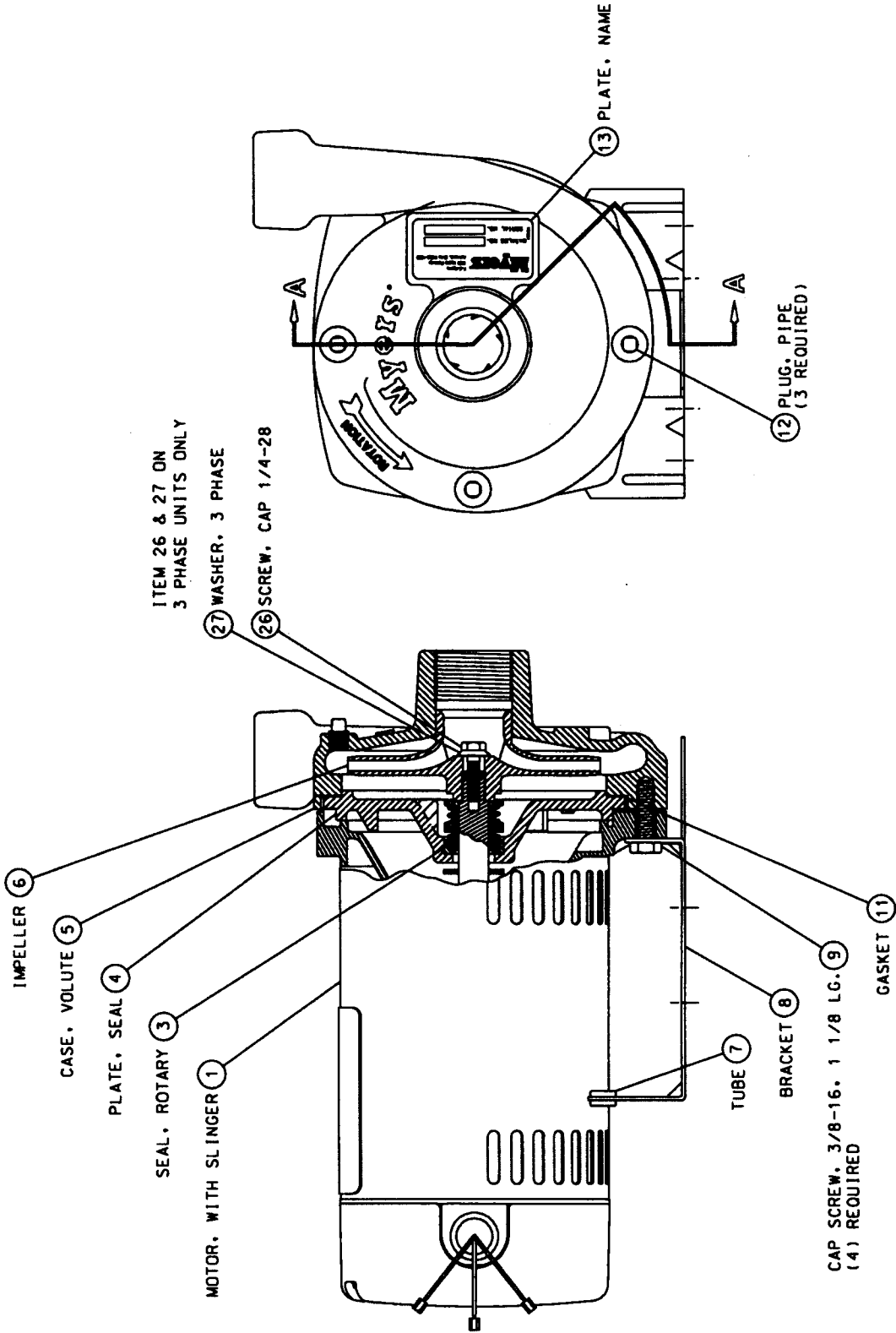

## SERVICE

### TROUBLE SHOOTING GUIDE

A				
B				
C				
D				
POSSIBLE CAUSE OF PROBLEM	D	C	B	A
1. Pump not properly primed; repeat priming operation				X
2. Discharge head too high. Check total head with gauge at pump inlet and discharge. (With no water, the gauge at discharge would show shut-off pressure.)			X	X
3. Excessive volume being discharged. Throttle discharge valve.		X		
4. Suction lift too high. Check with vacuum gauge. This should not exceed 15 feet.	X		X	X
5. Air leak in suction line. Check line under pressure to find leak.	X	X	X	X
6. Air pocket in suction line. Check line for proper slope.	X			X
7. Impeller or suction line plugged.		X	X	x
8. Impeller and volute case badly worn. Disassemble pump if clearance on diameter is over .030", replace worn impeller and worn volute case.		X	X	
9. Suction strainer plugged. Clean strainer.	X			
10. Impeller diameter too small for condition required.		X	X	
11. Seal leaking - seal is worn or seal face cocked. Replace with new seal and carefully follow directions.				